

For use with the following starting serial numbers:

BDHP1250 BDHP12B

BDHP1400 BDHP14B

BDHP 12.5 & 14 Disc Harrow



ATTENTION:
ALL WARRANTY WORK MUST BE APPROVED
BY BROWN MFG. CORP.
BEFORE WORK BEGINS

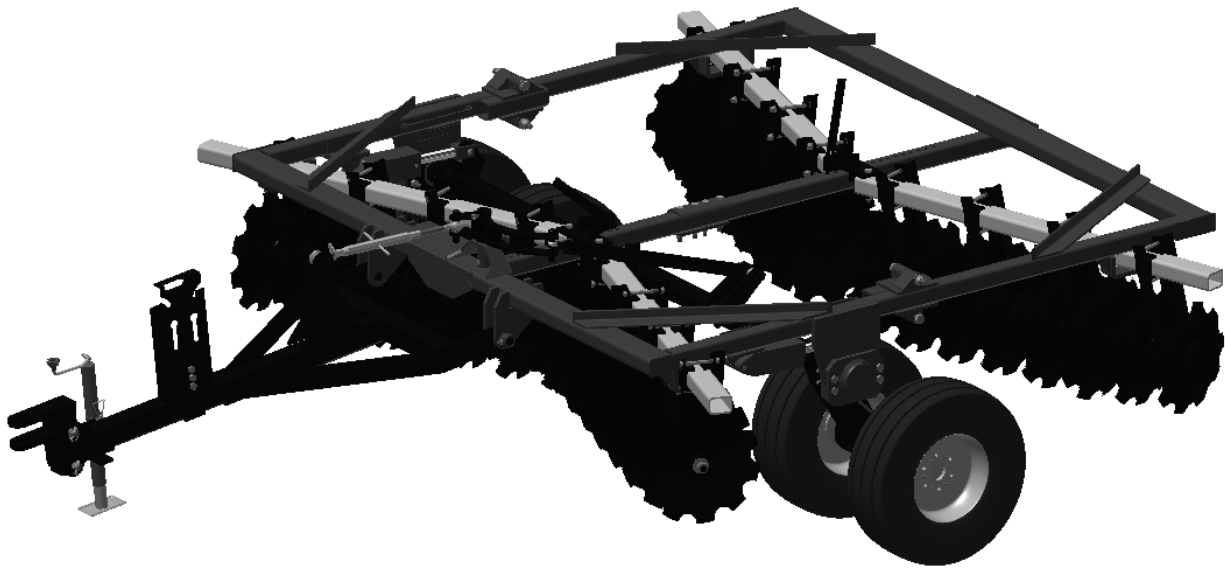

Owner/Operator Manual



HEAVY DUTY SINCE 1944

6001 E. Hwy 27 - Ozark, AL 36360

334.795.6603 - Fax: 334.795.3029

www.brownmfgcorp.com

⚠ WARNING



Before operating your machine, stop and read this owners manual. Do not attempt to operate the unit until you fully understand the material covered in this manual. Without the knowledge contained in this manual, injury or death can result.

Copyright

Copyright ©2000 Brown Manufacturing Corporation. All photos and illustrations are property of Brown Manufacturing Corporation. This publication may be freely reproduced, either in whole or in part, provided that the content herein is not altered.

Cover

Pictured: Model BDHP-1250 disc harrow.

Disclaimer

Due to engineering improvements and revision of product specifications, the information contained in this manual is subject to change without notice.

Contents

Warranty.....	4
Registration.....	5
Equipment Safety.....	7
Assembly.....	12
Operation.....	17
Troubleshooting.....	18
Specifications.....	19
Replacement Parts.....	20

Warranty Statement

LIMITED WARRANTY

BROWN MANUFACTURING CORP. hereby warrants that Brown's products will be free from defects in material and workmanship under normal use according to the provisions and limitations herein set forth. All parts, specifically EXCLUDING expendable 'wear' parts, that become unserviceable, due to defective material or workmanship, within three months / 90 days from date of the original retail purchase, shall, at Brown's option, be repaired or replaced.

LIMITATIONS

The obligations of Brown for breach of warranty shall be limited to products manufactured by Brown; (1) that are installed, operated, and maintained according to Brown's instruction furnished and/or available to the purchaser upon request; (2) that are installed according to all other applicable Federal, State, and local codes or regulations; and (3) that the purchaser substantiates were defective in material and workmanship notwithstanding that they were properly installed and correctly maintained as set forth and were not abused or misused. The obligation of Brown shall be limited to replacing or repairing the defective product, at the option of Brown. Brown shall not be responsible for any labor or cost of removal or repairing or reinstallation of its products and shall not be liable for transportation costs to and from its plant in Ozark, Alabama. Use of parts for modification or repair of the product or any component part thereof not authorized or manufactured by Brown specifically for such product shall void this warranty. This warranty shall not apply to any damage to or defect in the Brown's products that is directly or indirectly caused by; (1) FORCE MAJEURE, act of GOD, or other accident not related to an inherent product defect; or (2) abuse, misuse, or neglect of the such product, including any damage caused by improper assembly, installation, adjustment, or faulty instruction of the purchaser. **OTHER THAN AS EXPRESSLY SET FORTH HEREIN ABOVE, BROWN MAKES NO OTHER WARRANTY, EXPRESS OR IMPLIED, WITH RESPECT TO ANY OF BROWN'S PRODUCTS, INCLUDED BUT NOT LIMITED TO ANY MERCHANTABILITY OR FITNESS FOR A PARTICULAR PURPOSE. IN NO EVENT SHALL BROWN BE RESPONSIBLE FOR ANY INCIDENTAL OR CONSEQUENTIAL DAMAGES OF ANY NATURE SUFFERED BY PURCHASER OR ANY OTHER PERSON OR ENTITY CAUSED IN WHOLE OR IN PART BY ANY OF BROWN'S PRODUCTS.** Any person or entity to whom this warranty extends and who claims breach of warranty against Brown must bring suit thereon within one year from the date of occurrence of such breach of warranty or be forever barred from any and all legal or other remedies for such breach of warranty. Brown is not responsible for and hereby disclaims any undertaking, representation, or warranty made by any dealer, distributor, or other person that is inconsistent with or in any way more expensive than the provisions of this limited warranty. This warranty grants specific legal rights and shall be read in conformity with applicable state law. In some jurisdictions, the applicable law mandates warranty provisions that provide greater rights than those provided for herein. In such case, this limited warranty shall be read to include such mandates provisions; and any provision herein that is prohibited or unenforceable in any such jurisdiction shall, as to such jurisdiction, be ineffective to the extent of such prohibition or unenforceable without invalidating the remaining provisions and without affecting the validity or enforceability of such provisions in any other jurisdiction.

STATEMENT OF POLICY

In accordance with our established policy of constant improvement, we reserve the right to amend these specifications at any time without notice.

WARRANTY BY MANUFACTURER

Dealer/distributor understands and agrees that the manufacturer extends only the following warranty to its customers. In the event dealer/distributor extends any additional warranty such as enlarging the scope or period of warranty or undertaking a warranty of fitness for any particular purpose or obligation not encompassed in manufacturer's warranty, dealer/distributor shall be solely responsible therefore and shall have no recourse against manufacturer with respect thereto.

Owner Registration

To place the manufacturer's warranty into effect, the registration card below must be mailed within thirty (30) days after receiving equipment.

Owner Registration



Important: Please record your Model, Serial Number, Date Purchased, and Dealer Information for future reference.

Model: BDHP- _____

Serial No.: _____

For further information:
Brown Manufacturing Corp.
6001 E. Hwy 27
Ozark, AL 36360

Date Purchased: ____ / ____ / ____

Dealer: _____

Phone: (334) 795-6603
Toll Free: (800) 663-8909
FAX: (334) 795-3029

www.brownmfgcorp.com
brown@brownmfgcorp.com

Owner Registration



Important: To place the manufacturer's warranty into effect, this card must be mailed within thirty (30) days after receiving equipment.

Name: _____

Address: _____

City: _____ State: _____

Model: BDHP- _____

Return to:
Brown Manufacturing Corp.
6001 E. Hwy 27
Ozark, AL 36360

Serial No.: _____

Date Purchased: ____ / ____ / ____



Dealer: _____

Please use envelope.

Equipment Safety

Warning: Read this manual before operation.

Operators of the equipment must read and understand this manual. Failure to read this manual and follow these safety and operating instructions could result in serious bodily injury or even death.

 WARNING	
	<p>Before operating your machine, stop and read this owners manual. Do not attempt to operate the unit until you fully understand the material covered in this manual. Without the knowledge contained in this manual, injury or death can result.</p>

Equipment Safety

Recognize safety information

This is the safety alert symbol. When you see this symbol on your equipment or in this manual, be alert to the potential for personal injury or injury to others.



Understand signal words

DANGER indicates an imminently hazardous situation which, if not avoided, will result in death or serious injury



WARNING indicates a hazardous situation which, if not avoided, could result in serious injury or death.



CAUTION indicates a potentially hazardous situation which, if not avoided, may result in minor or moderate injury.



NOTICE indicates information considered important but not directly hazard related. (e.g. security, hygiene, equipment or property damage).



Follow safety instructions

- Read owner/operator manual.
- Replace missing or damaged safety decals.
- Safety decals and this manual must be considered a permanent part of your equipment.
- Should ownership of the equipment be transferred, this manual must also be transferred.
- Unauthorized modifications to the equipment are not recommended. This could impair the function, safety, and life of the machine.
- For any part of this manual that you do not understand, contact your dealer or Brown Manufacturing Corporation at (800) 633-8909.
- All implements with moving parts are potentially dangerous. Due to this fact, there is no substitute for a safe, knowledgeable operator. It is important that all persons operating this equipment read, understand, and follow the instructions provided in this manual.





DO NOT OPERATE THIS UNIT IF YOU ARE UNDER THE INFLUENCE OF ALCOHOL, ILLEGAL DRUGS, OR ANY PRESCRIPTION OR OVER THE COUNTER MEDICATIONS THAT COULD CAUSE DROWSINESS, DIZZINESS, DISORIENTATION AND/OR IMPAIR YOUR ABILITY IN ANY WAY TO SAFELY OPERATE THE UNIT.

DO NOT OPERATE THIS UNIT IF YOU SUFFER FROM ANY PHYSICAL CONDITION OR DISABILITY THAT WOULD IMPAIR YOUR ABILITY TO OPERATE IT SAFELY.





Equipment Safety

Safety Decals

The following safety decals should be attached to the equipment at all times. Should any decal become damaged or lost, it is the responsibility of the owner to replace it. Additional decals may be obtained from the manufacturer.

 WARNING	 ADVERTENCIA
	<p>Antes de probar la unidad por primera vez deben remitirse a las instrucciones contenidas en el manual.</p>
<p>Read and understand owner's manual before operating unit.</p>	 ADVERTISSEMENT <p>S'assurer de bien comprendre toutes les consignes du manuel de propriétaire avant d'utiliser la unité.</p>

Part No.: SD-010.

 DANGER	 PELIGRO
	<p>CUCHILLAS ROTATIVAS</p> <ul style="list-style-type: none"> •Guarden las monas y los pies lejos de las cuchillas. •No se acerquen a la máquina estando funcionando el motor.
<p>ROTATING BLADES</p> <ul style="list-style-type: none"> •Keep hands and feet away from blades. •Stay away from machine when engine running. 	 DANGER <p>LAMES ROTATIVES</p> <ul style="list-style-type: none"> •Garder les mains et les pieds éloignés des lames rotatives. •Rester loin de la machine quand le moteur tourne.

Part No.: SD-012A.

Equipment Safety

Warning! Transport with care.

Before transporting to a new location, make certain that the slow-moving vehicle (SMV) emblem is installed and is clearly visible. Use flashing lights and follow local traffic regulations.

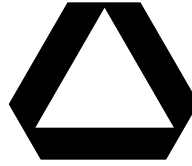

WARNING

Transport with care. Use slow-moving vehicle emblem and flashing light. Follow local traffic regulations.

Danger! Protect bystanders, clear work area of debris.

Do not operate the cutter near people. Debris can be thrown hundreds of feet. Clear work area of foreign objects such as wire, glass, and other debris. Debris thrown by the cutter can cause serious injury or death.

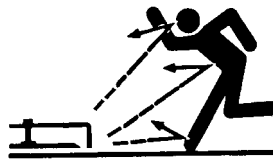

DANGER

Do not operate cutter near bystanders. Clear work area of debris before operating.

Warning! Parking and dismounting.

The rotating parts of this cutter continue to rotate even after the PTO has been disengaged. The operator should remain seated until rotation has stopped. He should then set the brake, turn off the engine, and remove the key. See tractor manual for proper parking procedure.

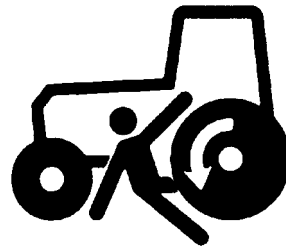

WARNING

Wait for all rotation to stop before dismounting tractor.

Caution! Avoid fires.

Keep the machine clean of debris, trash, and any other flammable material.



CAUTION

Keep machine clean of debris. Flammable debris on machine poses fire hazard.

 **Warning!**
Fasten Seatbelt!
Before Starting Tractor!
Always Wear Your Seatbelt.



Equipment Safety

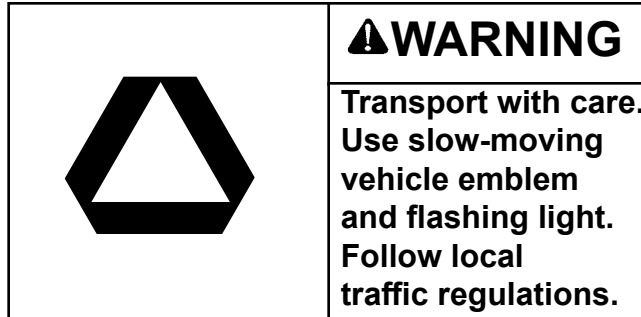

Warning! Transport with care.

Before transporting to a new location, make certain that the slow-moving vehicle emblem is installed and is clearly visible. Use flashing lights and follow local traffic regulations.

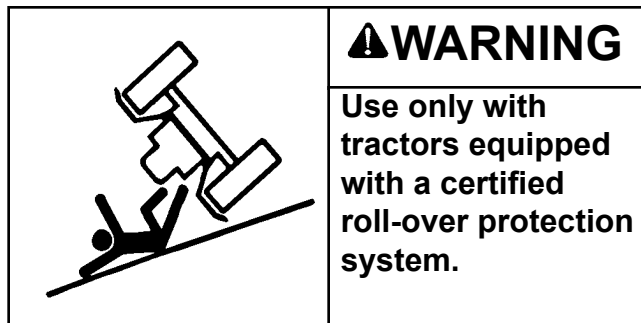

Warning! Roll-over protection.

Do not operate the harrow on any tractor not equipped with a certified roll-over protection system.

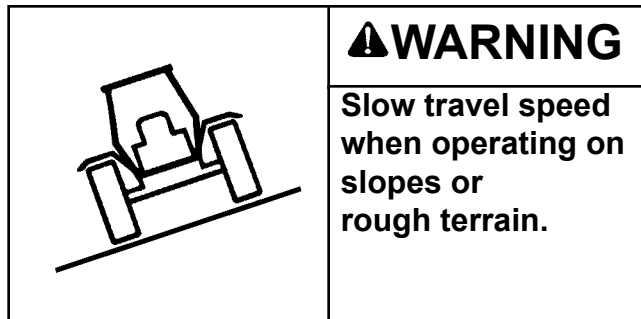

Warning! Slopes and rough terrain.

When operating on slopes or rough terrain, slow travel speed. Do not operate in an area where the tractor could roll over. **Be sure to fasten safety belt when operating tractor!**

SMV Decal Placement

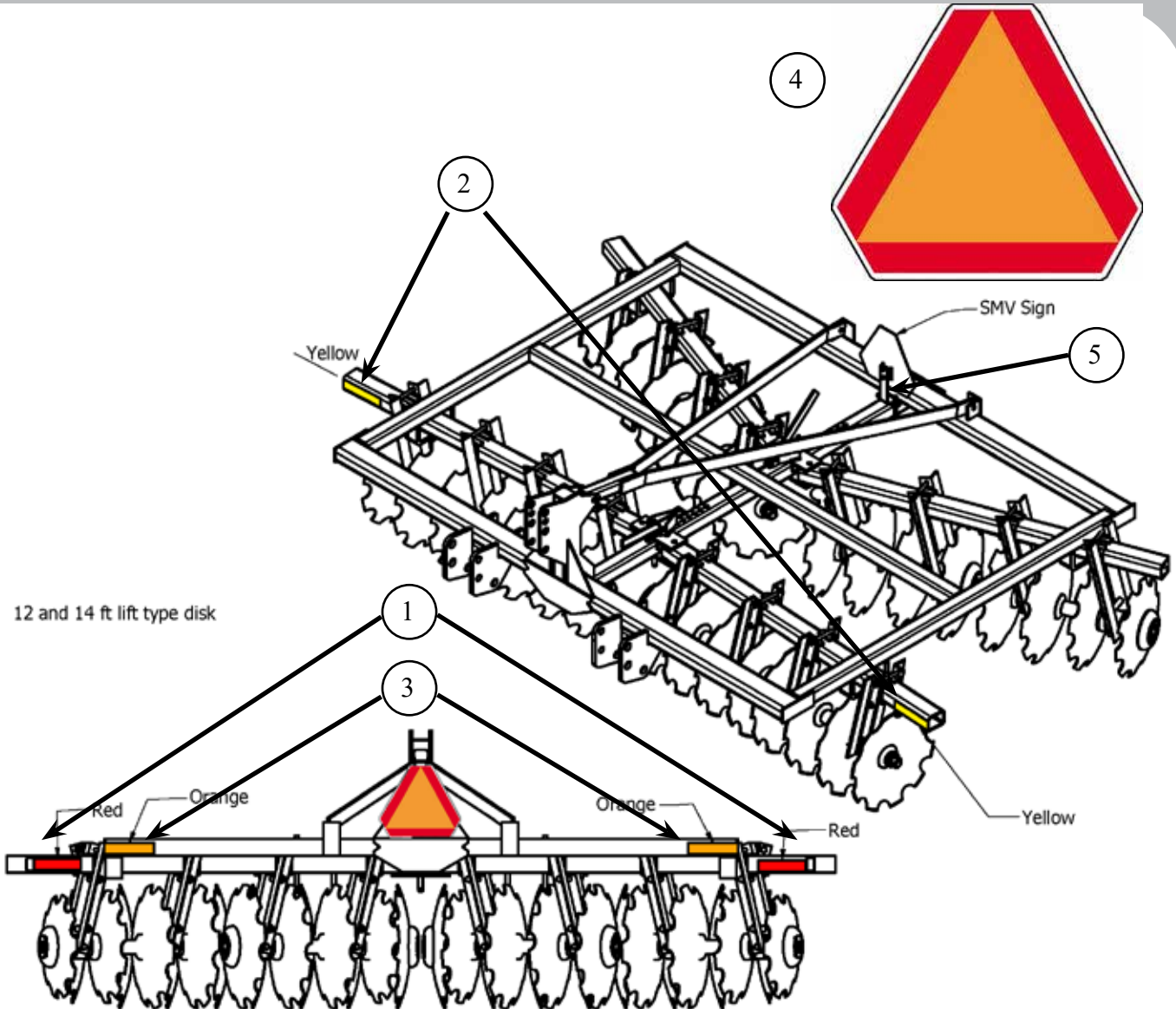

Ref. No.	Part No.	Qty Required	Description
1	500-237-0001	2@9" each	Red Retroreflective Tape - 2" Wide
2	500-237-0002	2@9" each	Yellow Retroreflective Tape - 2" Wide
3	237-0001	2	Red-Orange Fluorescent Tape
4	225-0054	1	SMV Sign
5	225-0055	1	SMV Sign Mount Bracket
5A	234-9020	1	SMV Mount

Assembly

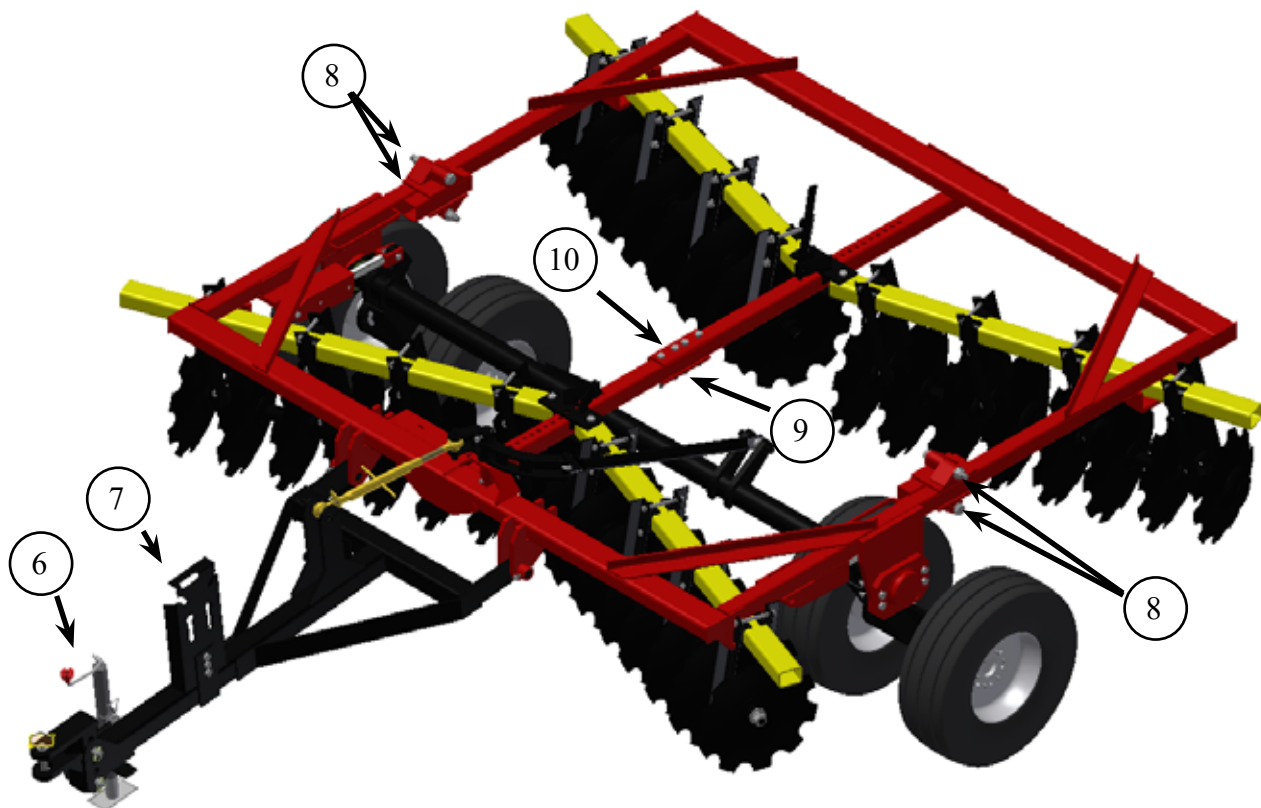

Ref. No.	Part No.	Qty Required	Description
6	225-0046	1	15" 5000 lbs. Jack
7	234-1400	1	Hose/Wire Capture
8	HC816C128Z	4	1 - 8 x 8 Grade 8 Zinc NC Bolt
8	WSA81Z	4	1" Flat Washer SAE Grade 8 Zinc
8	NNE81CZ	4	Nylon Lock Nut 1-8 Grade 8 NC Zinc
9	700-234-2080	1	Center Frame Tube Connector
10	700-234-2085	1	Top Center Frame Connector
10	HC812C80Z	4	3/4" x 5" Grade 8 Bolt NC, Zinc
10	NNE834CZ	4	Nylon Lock Nut 3/4-10 Grade 8 Zinc
10	WSA834Z	8	SAE Flat Washer Grade 8 Zinc

Model	Proper Gang Arm Length
BDHP-1250 (front/rear)	72" gang arm (234-1201)
BDHP-1400 (front/rear)	80" gang arm (234-1401)

Assembly

BEARING HANGER LEANS OUTWARD
ON FRONT GANGS

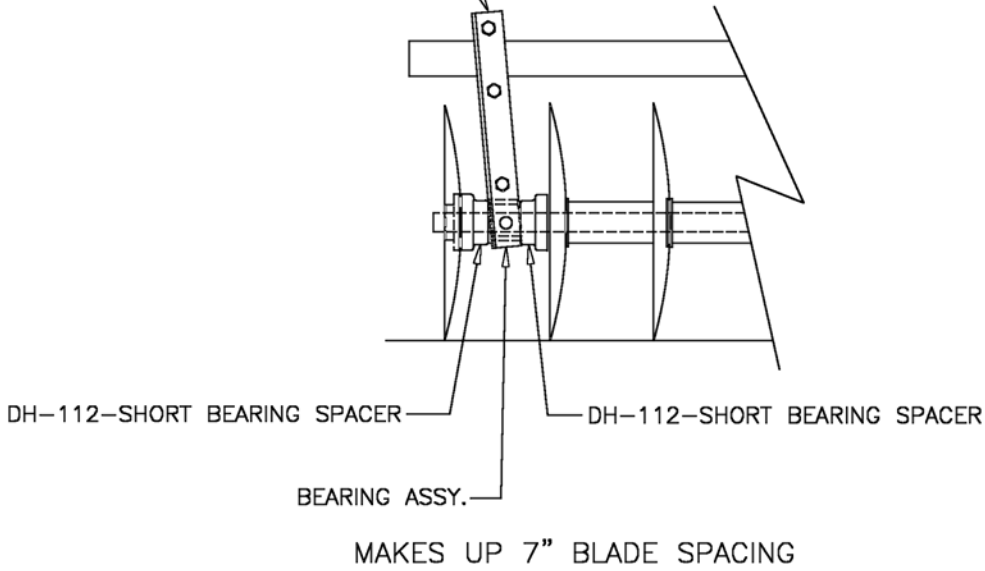

BEARING HANGER LEANS INWARD
ON REAR GANGS

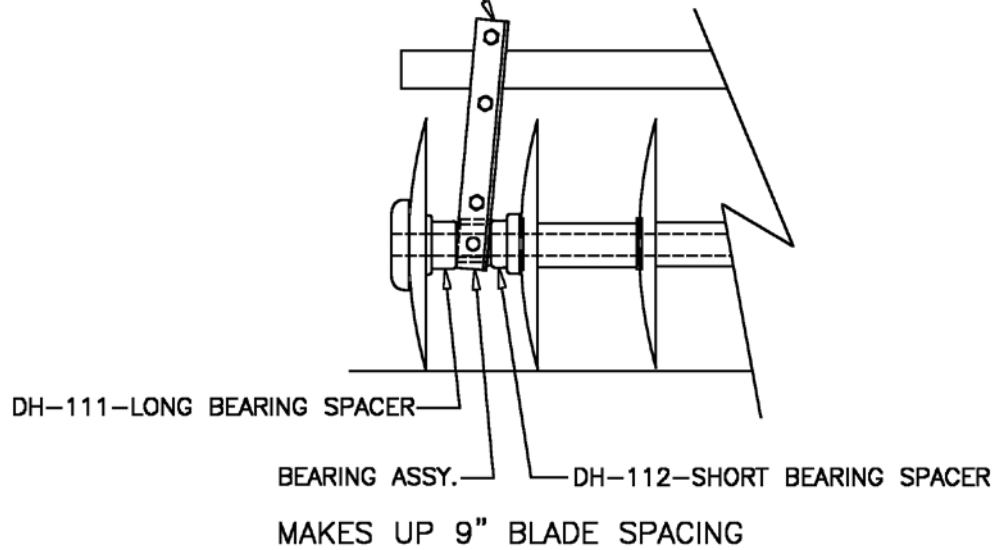

Assembly

Brown Disc Harrows

Brown Pull Type Disc Harrows come partially assembled, please check all fasteners to ensure correct torque before use and after two hours of use.

Tongue assembly

Step 1: Bolt A-frame braces to the outside of the top of A-frame in the back holes.

Step 2: Bolt A-frame braces into rear holes of lift ears on frame.

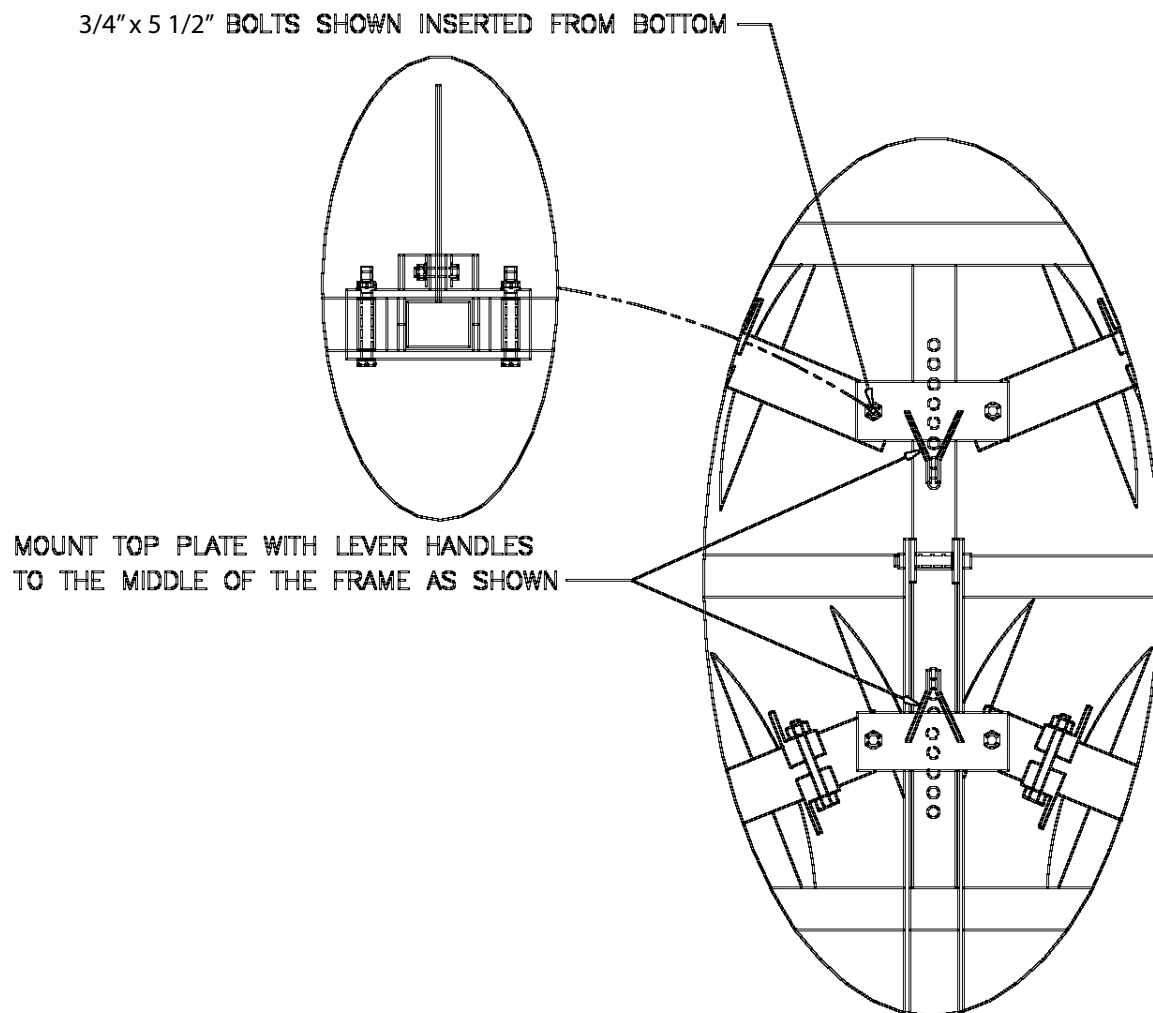

Assembly

Blade Scraper Assembly

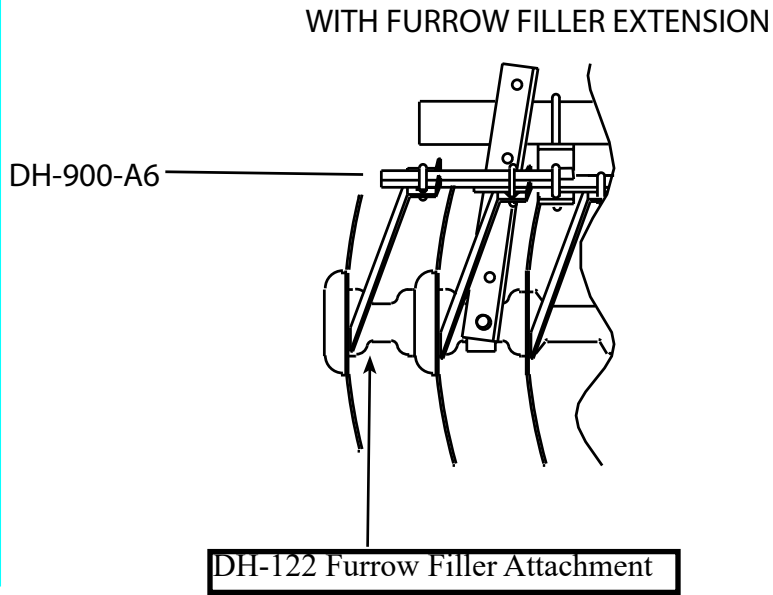
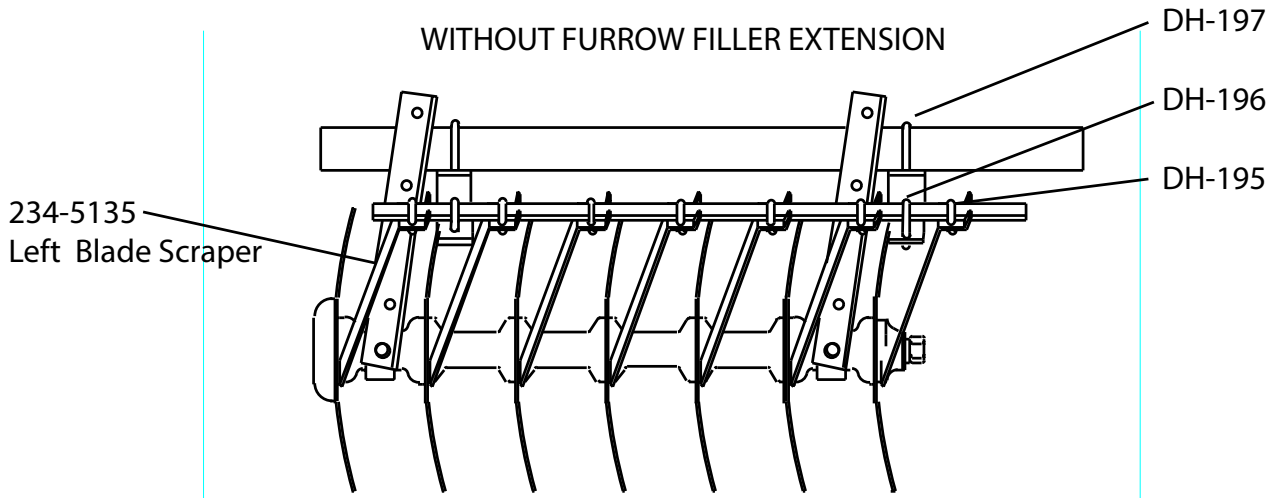

Operation



Before hitching harrow to your tractor, make sure all safety devices are installed on the tractor.

Please follow all safety instructions and procedures.

Attach equipment to tractor.

Be sure the tractor is equipped with the correct category hitchpins, top link, etc.

Be extremely careful when positioning tractor to hitch to the equipment.



Caution! Never allow anyone between the tractor and the equipment during the hitching process.

Adjust cutting depth.

Be sure the tractor engine is off, key is removed, and all movement of the tractor has stopped before dismounting to make adjustments.

Using the center link adjustment set the equipment so that the front and rear gangs are cutting at the same depth. Set the wheel lift stop at the required position to maintain a uniform depth.

Operating speed

Proper operating speed for equipment will depend upon the soil conditions and the particular application.



Warning! Avoid personal injury. Never allow anyone to ride on the tractor or harrow.

Remember: The safe operation of this equipment is the responsibility of the operator. The operator should be familiar with both the tractor and the equipment. He should read and understand all applicable operator manuals and follow all safety practices.

Troubleshooting

Problem	Possible Cause(s)	Possible Solution(s)
Leaving center ridge	<ol style="list-style-type: none"> 1. Excessive Speed 2. Rear gangs cut too deep 3. Top link too long 	<ol style="list-style-type: none"> 1. Reduce speed 2. Reduce gang angle 3. Shorten top link
Leaving center valley	<ol style="list-style-type: none"> 1. Insufficient speed 2. Rear gangs too shallow 3. Top link too short 4. Rear gangs too far apart. 	<ol style="list-style-type: none"> 1. Increase speed 2. Increase gang angle 3. lengthen top link 4. Adjust gap in rear gangs
Side draft	Harrow not level side-to-side	Level draft lengths
Tractor wheel slippage	Not enough ballast	Add weights or liquids to tractor
Plugging	<ol style="list-style-type: none"> 1. Extremely wet soil 2. Gangs set at too great an angle 3. Not using scrapers 	<ol style="list-style-type: none"> 1. Allow soil to dry 2. Reduce angle 3. Install scrapers
Outside furrows too deep	Not using furrow fillers	Install furrow fillers
Poor penetration	<ol style="list-style-type: none"> 1. Insufficient gang angle 2. Lift set too high 	<ol style="list-style-type: none"> 1. Increase gang angle 2. Reduce lift height

Specifications

Model	No./Dia. Blades	Spacing F/R	Approx. Width Cut	Weight	No. Bearings
BDHP-1250-3422	34/22	9/9	13'2"	3829 lbs.	16
BDHP-1250-3822	38/22	9/7	12'8"	3845 lbs.	16
BDHP-1400-3822	38/22	9/9	14'6"	4043 lbs.	16
BDHP-1400-4222	42/22	9/7	13'6"	4074 lbs.	16

Standard Features

3" x 3", 3" x 4" high tensile steel tube frame

Triple-sealed ball bearings

Self-aligning bearing housings

1 1/8" axles

Cast iron spacers

Notched blades

Options

Part No.

Balk Buster assembly

DH-191A

Scraper Assembly

Last 7 digits of model [xxx]-[xxxx] FR (front and rear) or R (rear) i.e. 600-1620FR

Furrow Filler adapter
(two needed)

DH-122A - Disc blade is not included with this item.

Assembly

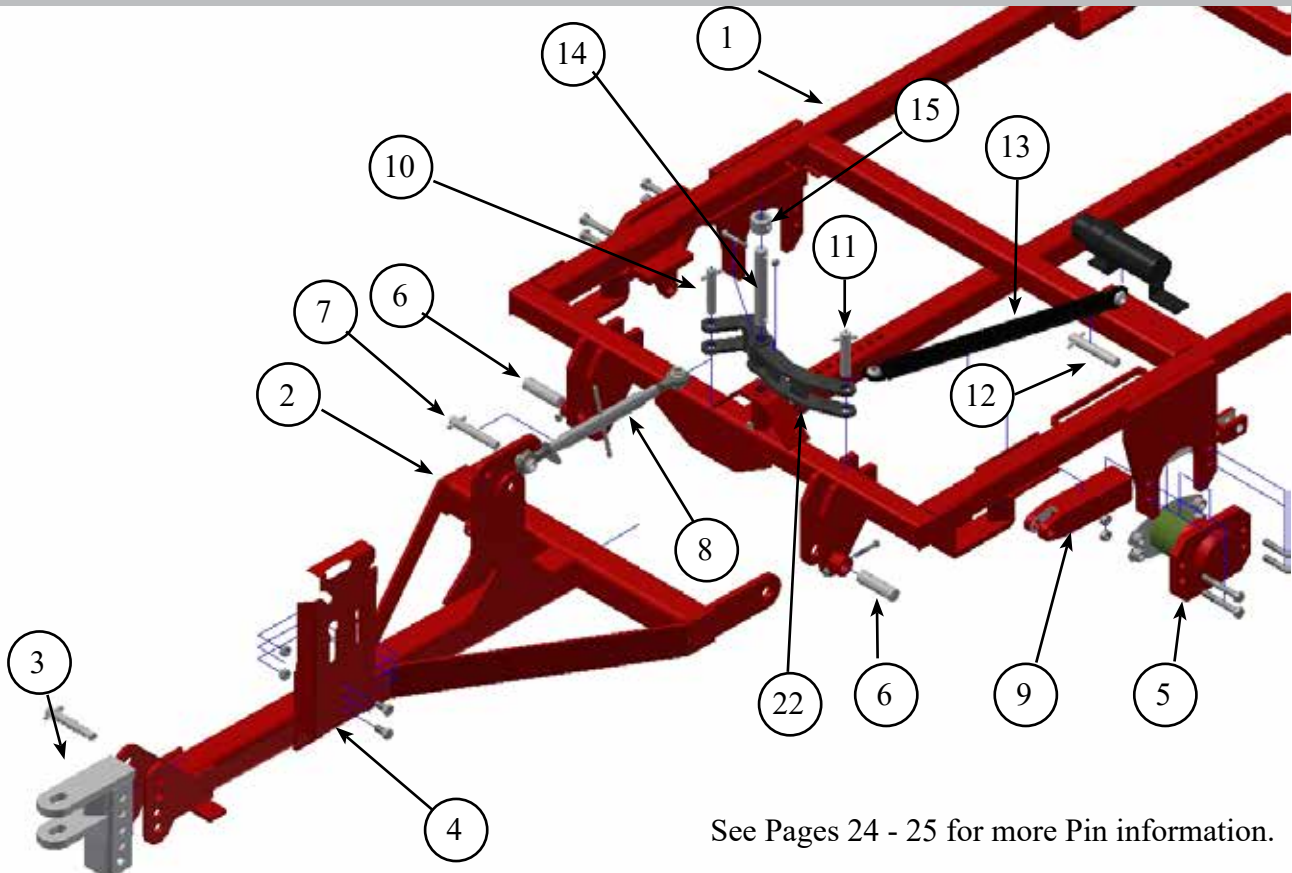

See Pages 24 - 25 for more Pin information.

Ref. No.	Part No.	Qty Required	Description
1	234-1255A/B	1	12/14 ft Disc Harrow Frame, Pull, Front/Rear
2	234-1020	1	Tongue Assembly - Pull Type
3	234-1070	1	Clevis Drawbar Hitch - uses TC-126K pins
4	234-1400	1	Hydraulic Hose Tender
5	234-1030	2	Axle Retainer
6	700-234-1895	2	Tongue to Frame Pin, 1 7/16" x 5" CRR
7	234-3105	1	Top Link Cat II Pin Extra Length, Tongue Attachment
8	255-2500	1	Top Link, Cat II
9	255-0360	2	Hydraulic Lift Cylinder 3000 PSI
10	234-3100	1	Top Link Cat II Pin Extra Length
11	234-3110	1	Lower Link Cat II Pin Extra Length
12	234-3115	1	Lower Link Cat II Pin Extra Length, To Axle
13	234-2120	1	Leveling Bar Pull Type
14	700-234-1890	1	Pivot Shaft for Lift Leveling Mech.
15	61-C	1	Pin Collar

Assembly

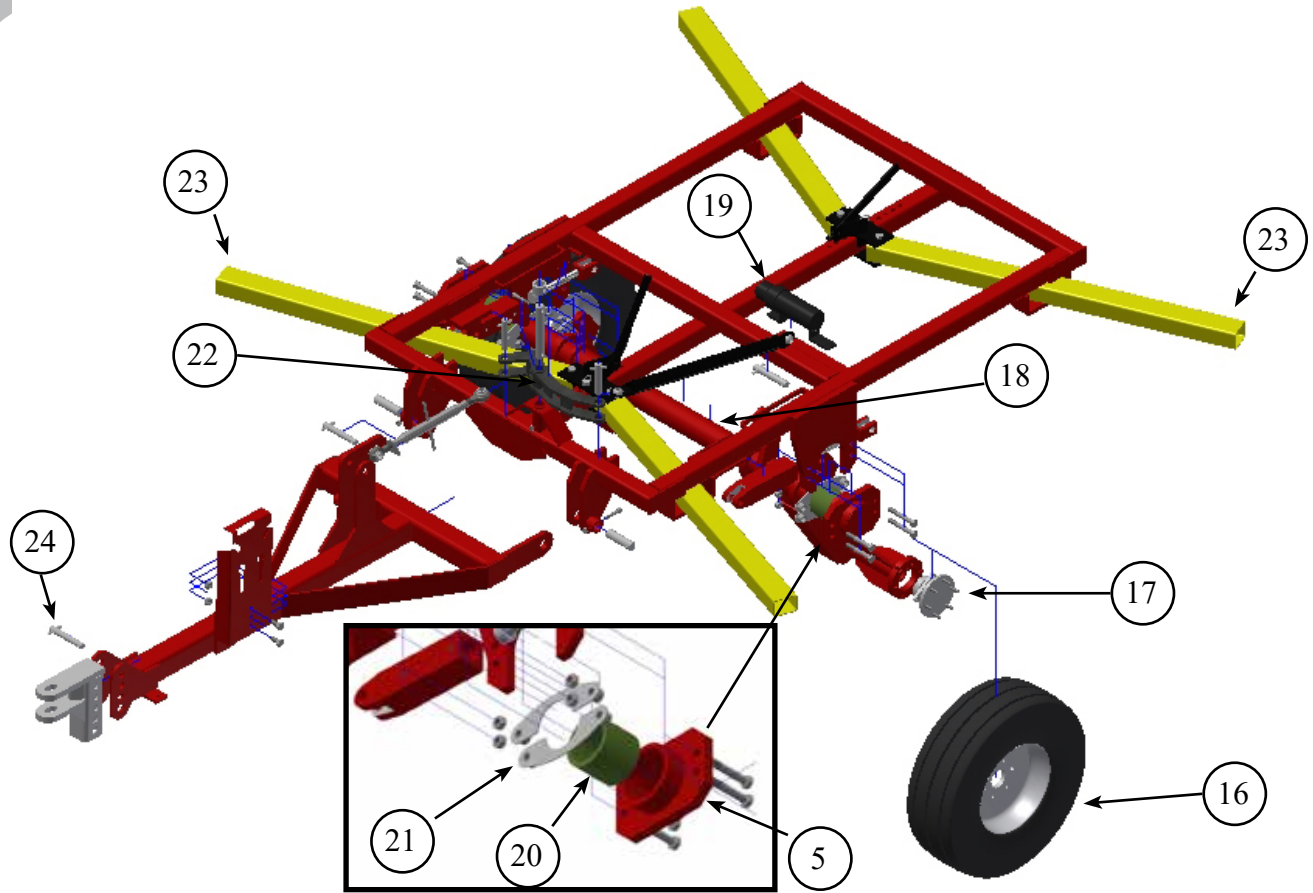

Ref. No.	Part No.	Qty Required	Description
16	234-5560	4	Tire & Wheel 9.5L15 HSP31 8 Ply 6 on 5.5" BC
17	255-6500	4	Unit Bearing Hub 6 on 5.5 BC
not shown	MCS14F45Z	3 per bearing	Unit Bearing Mounting Bolts M14x1.5x45x10.9Gr.
not shown	LNM1415Z	6 per wheel	Wheel Lug Nut 14mm x 1.5 Plated
18	234-1060	1	Axle-Lift Arm - Pull Type for 12.5 and 14 foot models
19	MH-01	1	Manual Holder Tube
not shown	NNE516CZ	2	Nut, Nylon Lock 5/16" Zinc - for Manual Holder MH-01
not shown	CB5516C16Z	2	Bolt, 5/16" X 1" USS Carriage - for Manual Holder MH-01
20	234-0400	2	Oil Filled Nylon Bushing
21	234-2110	4	Axle Bushing Capture
22	234-1015	1	Leveling Adjustment Pivot 12.5 and 14 foot
23	234-1201	4	72" gang arm for BDHP-1250
23	234-1401	4	80" gang arm for BDHP-1400
24	TC-126K	2	Hitch to Tongue

Replacement Parts



Ordering replacement parts

Please contact the nearest Brown dealer for replacements parts. They will be able to meet most of your equipment needs.

Replacement Parts

Ref. No.	Part No.	Qty Required	Description
1	DH-95	4	31" Axle For 4 Blades @ 9" or 5 Blades @ 7" spacing
	DH-98	2	37 1/2" Axle 6 Blades @ 7" spacing
	DH-99	2	39 3/4" Axle 5 Blades @ 9" spacing <i>1 1/8" Dia. Axles, Less Nuts And Washers</i> <i>(Note: Axle Lengths Measured under Head To End.)</i>
2	DH-107A		Bumper Washer With Holes For Furrow Filler
3	DH-111		Long Bearing Spacer (4 1/2")
4	DH-113		Bearing Housing
5	DH-115		Ball Bearing
4,5,6	DH-115A		Ball Bearing Assembly
6	DH-117		Lock Ring
7	DH-112		Short Bearing Spacer (2 5/8")
8	DH-106		9" Spacer
9	DH-105		7" Spacer
10	DH-108		End Nut Washer
11	DH-204		Square Hole Washer
12	WUS118Z	var	1 1/8" Flat Washer
13	NNE8118CZ	var	1 1/8" Nylon Lock Nut Grade 8
14	HN5118CZ		1 1/8" Standard Nut
15	DH-122A		Furrow Filler Adapter Assembly (does not include disc blade)
16	DH-122		Furrow Filler Adapter
17	DH-123		Furrow Filler Washer
18	LOC1Z		1" Lock Washer
19	HN51CZ		1" Nut
20	DH-116-18		18" 7 Guage Disc Blade
	DH-116-20		20 " 7 Guage Disc Blade
	DH-116-22		22"7 Guage Disc Blade

Ordering replacement parts

Please contact the nearest Brown dealer for replacements parts. They will be able to meet most of your equipment needs.

Replacement Parts

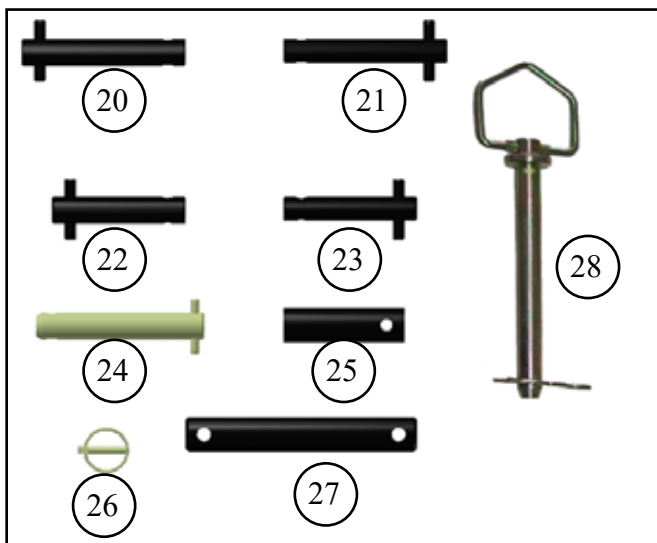
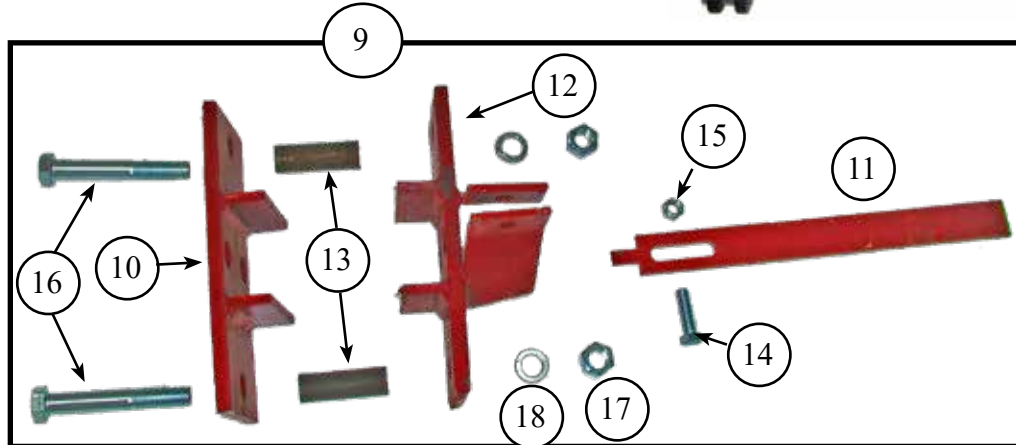
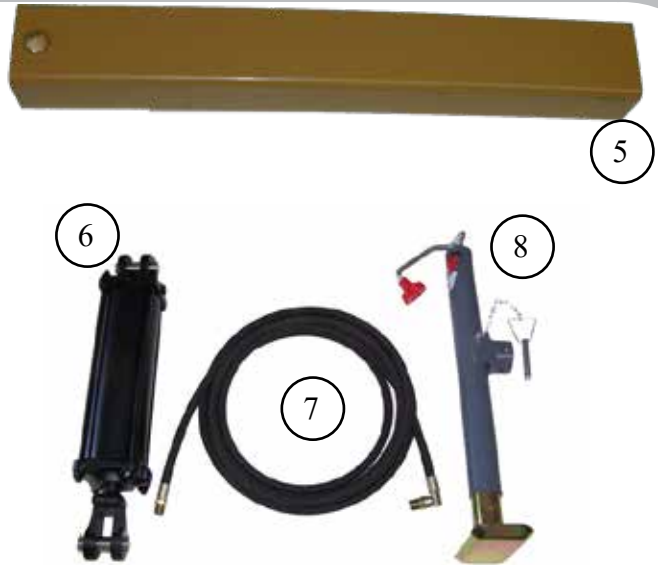
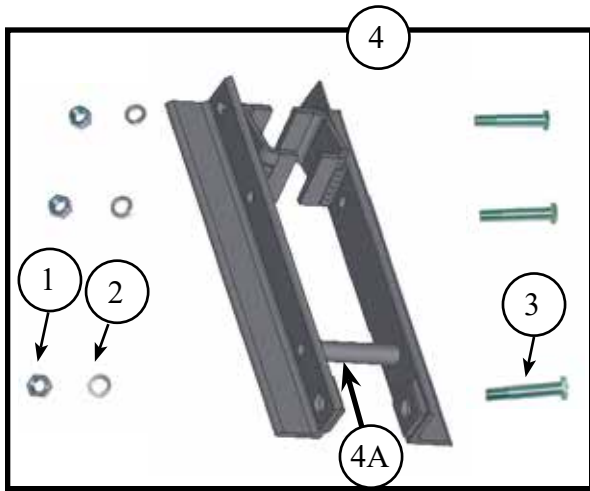

Ordering replacement parts

Please contact the nearest Brown dealer for replacements parts. They will be able to meet most of your equipment needs.

Replacement Parts

Ref. No.	Part No.	Qty Required	Description
1	HN258CZ	3 per Hanger Assy	Nut, Hex 5/8" NC GR2 Zinc
2	LOC58Z	3 per Hanger Assy	Washer, Lock 5/8" Zinc
3	HC510C104Z	3 per Hanger Assy	Bolt, 5/8" X 6 1/2" NC GR5 For Bearing Hangers
4	DH-1254B	8	Bearing Hanger Assembly with fasteners.
4A	DH-1254A	1 per Hanger Assy	Bearing Hanger Spacer
5	234-1201	4	72" gang arm for BDHP-1250
	234-1401	4	80" gang arm for BDHP-1400
6	233-0360	2	Hydraulic Cylinder, 3" x 6"
7	234-6150	1	Hydraulic Hose Kit for 12.5 and 14 foot BDHP Harrows
8	225-0046	1	Jack, 15" 5000 lb. Round Pipe Mount Swivel
9	DH-153A	2	Gang Adjuster Assembly
10	DH-153	2	Gang Arm Pull Adjuster Bottom Plate
11	DH-154	2	Gang Arm Adjuster Lever
12	DH-155	2	Gang Arm Adjuster Top Plate
13	DH-156	2	Gang Arm Adjuster Bushing (2 required per gang)
14	HC58C28Z	1 Per Assembly	Bolt, 1/2" X 1-3/4" NC GR5
15	NSB50CZ	1 Per Assembly	Nut, Stover Lock 1/2" NC Zinc
16	HC512C88Z	2 Per Assembly	Bolt, 3/4" X 5 1/2" NC GR5 - Gang Adjuster
17	HN534CZ	2 Per Assembly	Nut, Hex 3/4" NC GR5 Zinc
18	LOC34Z	2 Per Assembly	Washer, Lock 3/4" Zinc
19	234-1214	2	Cylinder Stop for Transport 12.5 and 14 foot 3" cylinder
	255-3825	2	Snap Pin 3/8" x 2 1/2" Zinc
20	234-3115	1	1-1/8 x 6-3/4" Link Pin, Leveler Arm to Axle
21	234-3105	1	1 x 6-3/4" Link Pin, Tongue to Top Link
22	234-3110	2	1-1/8 x 5-1/2" Link Pin, Pivot to Leveling Bar
23	234-3100	1	1 x 5-1/2" Link Pin, Top Link to Pivot
24	TC-126K	2	Cat II Lift Pin, Hitch to Tongue
25	700-234-1895	2	1-7/16 x 5" Tongue to Frame Pin
26	TC-126A	3	7/16" Lynch Pin
27	700-234-2040	1	1 7/16" x 9 1/2" Pivot Shaft
28	UT-207	3	3/4" Gang Adjuster Pin

Replacement Parts

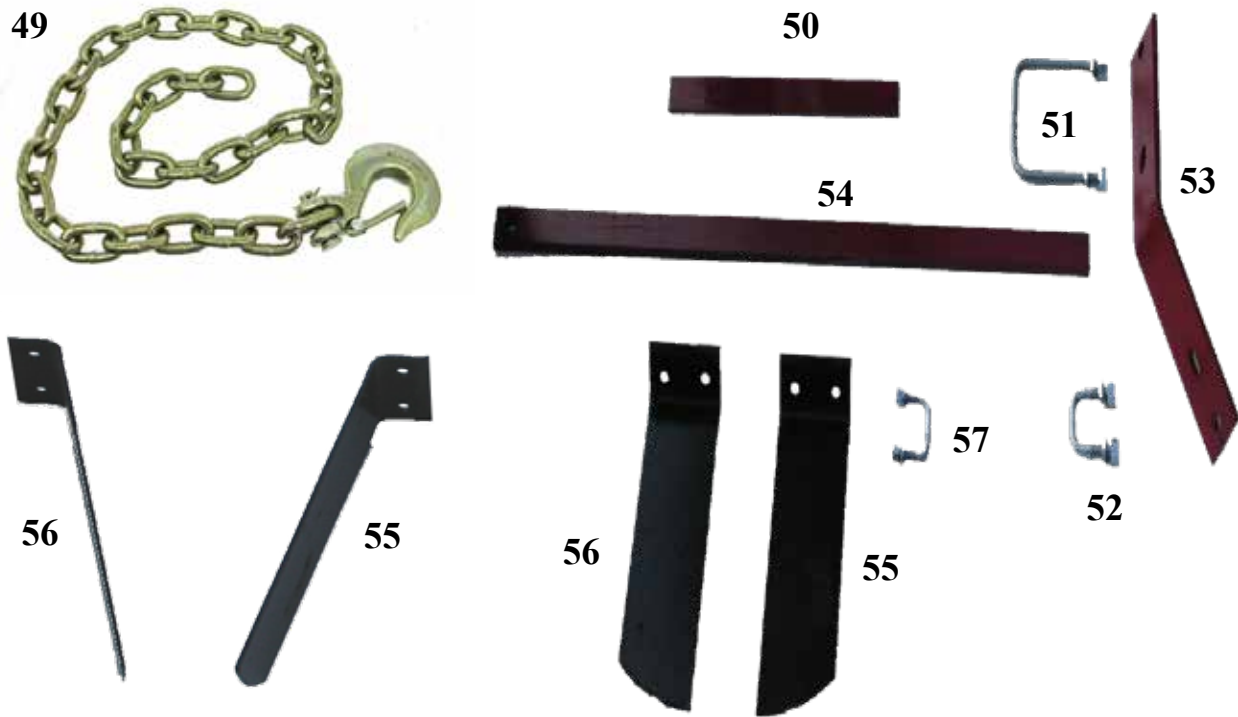

See Page 16 for Assembly Instructions of Scrapers

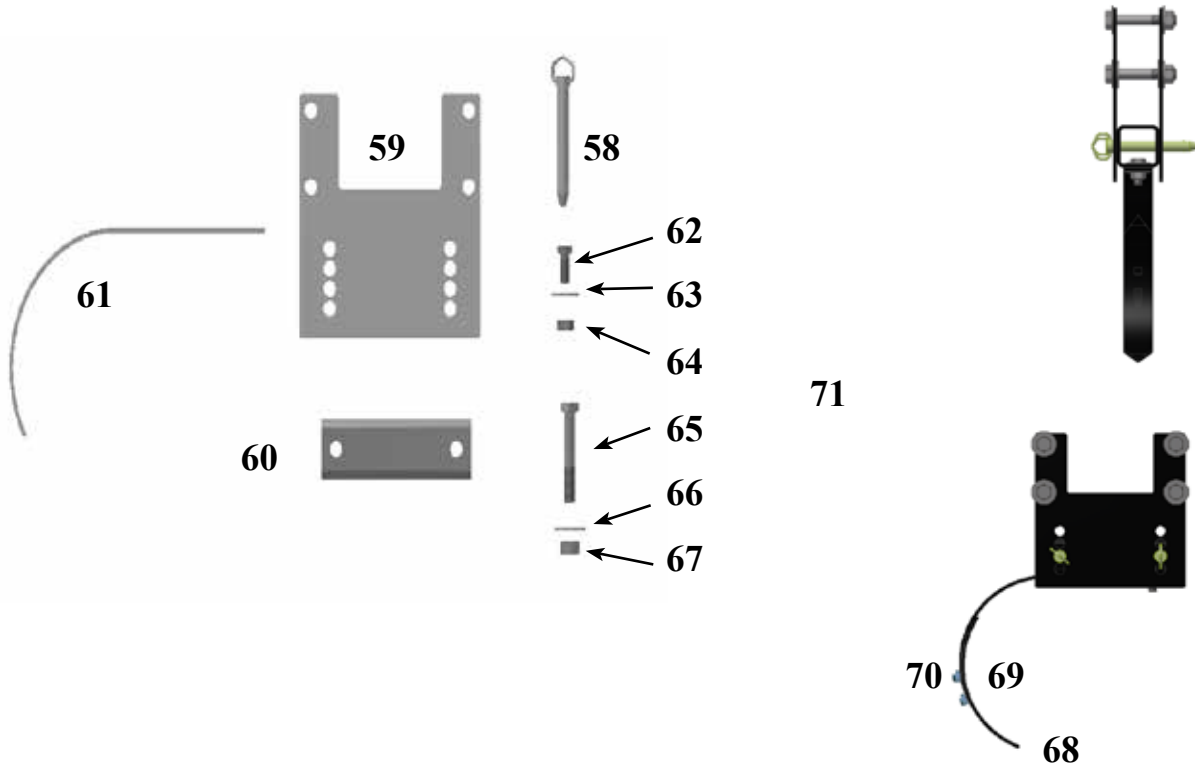

DH-191A Balk Breaker Assembly Parts Breakdown

Replacement Parts

Ref. No.	Part No.	Qty	Description
49	225-0027	1	Safety Chain
50	DH-900-A6		Furrow filler extension
51	DH-197		U-Bolt (1/2" x 4" x 4")
52	DH-196		U-Bolt (1/2" x 1 1/2" x 1 3/4")
53	DH-198		Scraper bar holder
54	DH-600-50 DH-750-03 DH-900-109		30" scraper bar for BDH-600 38" scraper bar for BDH-750 48" scraper bar for BDH-900
55	234-5135		Scraper blade left
56	234-5140		Scraper blade right
57	DH-195		U-bolt (3/8" x 1 1/2" x 1 1/2")
58	UT-207	2	Pull Pin 3/4 Inch
59	700-234-2090	2	Balk breaker mount bracket
60	700-234-3000	1	Balk breaker mount tube
61	DH-191	1	Balk breaker tine only
62	HC510C32Z	1	5/8" 11TPI X 2" Grade 5 Bolt
63	WUS58Z	1	5/8" USS Flat Washer, Zinc
64	NNE58CZ	1	Nylon Lock Nut 5/8" 11 TPI Zinc
65	HC512C72Z	4	3/4" 10TPI X 4 1/2" Grade 5 Bolt
66	WUS34Z	8	3/4" USS Flat Washer, Zinc
67	NNE34CZ	4	Nylon Lock Nut 3/4" 10 TPI Zinc
68	255-0750	1	Chisel Plow Point 11" x 2" x 5/16"
69	BPL6C20Z	2	Plow Bolt 3/8" - 16 TPI X 1 1/4 Zinc
70	NNE38CZ	2	Nylon Lock Nut 3/8" - 16 TPI Zinc
71	DH-191A	1	Balk Breaker Tine Complete Assembly, (Items 58 - 70)
			See Page 19 for blade scraper assembly part numbers.

Notes

Notes

[Blank area for notes]

Notes

Date	Page	Change Made
7/16/2024	26-27	Changed scraper blades to new part numbers.

Thank You for purchasing a Brown Disc Harrow.

Pull Type Tandem Disc Harrow 12.5 and 14 foot

Version 1.2.1
July 2024



6001 E. Hwy 27 - Ozark, AL 36360
334.795.6603 - Fax: 334.795.3029

www.brownmfgcorp.com